

Flex Rigid and Floating Shaft Couplings Size 1-7

When driving and driven shafts are widely separated, an unsupported or floating shaft is used to span the gap. The two couplings required at each end of that shaft consist of one half of a standard coupling bolted to a Rigid Hub, each unit called a Flex-Rigid Coupling. Usually, the rigid hubs are mounted on the driving and driven shafts so that the flex halves on the floating shaft may be replaced without disturbing the connected equipment.

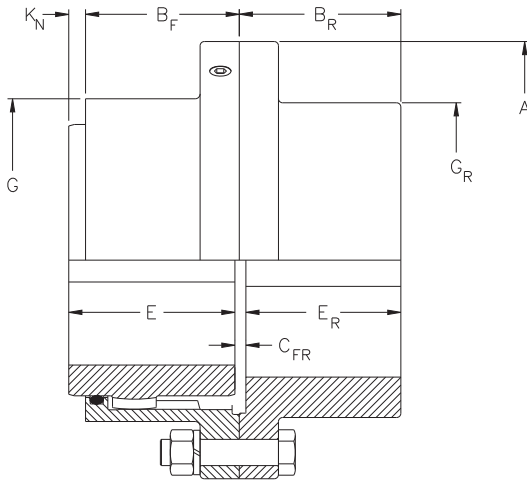

Coupling Type EB (Exposed Bolts) Part Numbers

Coupling Size	Flex Rigid Coupling			Rigid Hub		
	No Bore Part No.	Wt.	Finish Bore Part No.	No Bore Part No.	Wt.	Finish Bore Part No.
1	1H EB FR	10	1H EB FR FB	1 EB RHUB	5	1 EB RHUB FB
1 1/2	1 1/2H EB FR	19	1 1/2H EB FR FB	1 1/2 EB RHUB	9	1 1/2 EB RHUB FB
2	2H EB FR	31	2H EB FR FB	2 EB RHUB	15	2 EB RHUB FB
2 1/2	2 1/2H EB FR	55	2 1/2H EB FR FB	2 1/2 EB RHUB	27	2 1/2 EB RHUB FB
3	3H EB FR	83	3H EB FR FB	3 EB RHUB	40	3 EB RHUB FB
3 1/2	3 1/2H EB FR	126	3 1/2H EB FR FB	3 1/2 EB RHUB	65	3 1/2 EB RHUB FB
4	4H EB FR	184	4H EB FR FB	4 EB RHUB	90	4 EB RHUB FB
4 1/2	4 1/2H EB FR	252	4 1/2H EB FR FB	4 1/2 EB RHUB	124	4 1/2 EB RHUB FB
5	5H EB FR	371	5H EB FR FB	5 EB RHUB	119	5 EB RHUB FB
5 1/2	5 1/2H EB FR	418	5 1/2H EB FR FB	5 1/2 EB RHUB	200	5 1/2 EB RHUB FB
6	6H EB FR	504	6H EB FR FB	6 EB RHUB	250	6 EB RHUB FB
7	7H EB FR	792	7H EB FR FB	7 EB RHUB	370	7 EB RHUB FB

Coupling Type SB (Shrouded Bolts) Part Numbers

Coupling Size	Flex Rigid Coupling			Rigid Hub		
	No Bore Part No.	Wt.	Finish Bore Part No.	No Bore Part No.	Wt.	Finish Bore Part No.
1	1H SB FR	10	1H SB FR FB	1 SB RHUB	5	1 SB RHUB FB
1 1/2	1 1/2H SB FR	19	1 1/2H SB FR FB	1 1/2 SB RHUB	9	1 1/2 SB RHUB FB
2	2H SB FR	31	2H SB FR FB	2 SB RHUB	15	2 SB RHUB FB
2 1/2	2 1/2H SB FR	55	2 1/2H SB FR FB	2 1/2 SB RHUB	27	2 1/2 SB RHUB FB
3	3H SB FR	83	3H SB FR FB	3 SB RHUB	40	3 SB RHUB FB
3 1/2	3 1/2H SB FR	126	3 1/2H SB FR FB	3 1/2 SB RHUB	65	3 1/2 SB RHUB FB
4	4H SB FR	184	4H SB FR FB	4 SB RHUB	90	4 SB RHUB FB
4 1/2	4 1/2H SB FR	252	4 1/2H SB FR FB	4 1/2 SB RHUB	124	4 1/2 SB RHUB FB
5	5H SB FR	371	5H SB FR FB	5 SB RHUB	119	5 SB RHUB FB

① All finish bores and keyways per AGMA/ANSI 9112 commercial standard tolerances.

② Rigid hubs are furnished less fasteners.

Flex-Rigid Coupling Data

Coupling Size	Maximum Bore with Standard Keyway		Rating HP / 100 RPM	Torque Rating (lb.-in.)	Peak Torque Rating (lb.-in.)	Maximum Speed (RPM) ②	Dimensions						
	Flex	Rigid					A	BF	BR	CFR ①	E	ER	GR
1	1 5/8	2 1/4	12	7500	15000	14500	4 9/16	1 17/32	1 21/32	5/32	1 11/16	1 9/16	3
1 1/2	2 1/4	2 11/16	27	17000	34000	12000	6	1 25/32	1 15/16	5/32	1 15/16	1 27/32	3 13/16
2	2 7/8	3 3/8	50	31500	63000	9300	7	2 11/32	2 3/8	5/32	2 7/16	2 9/32	4 13/16
2 1/2	3 1/2	4	90	56700	113400	7900	8 3/8	2 11/16	3	3/16	3 1/32	2 29/32	5 3/4
3	4	4 3/4	160	101000	202000	6800	9 7/16	3 9/32	3 9/16	3/16	3 19/32	3 15/32	6 3/4
3 1/2	4 5/8	5 1/2	235	148000	296000	6000	11	3 27/32	4 1/8	7/32	4 3/16	4 1/32	7 3/4
4	5 1/2	6 3/8	375	236000	472000	5260	12 1/2	4 3/8	4 5/8	5/16	4 3/4	4 7/16	9
4 1/2	6 1/4	7 1/4	505	318000	636000	4770	13 5/8	4 27/32	5 1/4	11/32	5 5/16	5 1/16	10 1/8
5	7 1/8	8 1/2	700	441000	882000	4300	15 5/16	5 17/32	5 7/8	11/32	6 1/32	5 11/16	11 3/8
5 1/2*	8	8	920	580000	1160000	3880	16 3/4	6 7/32	7 5/32	11/32	6 29/32	6 31/32	10 3/4
6*	8 7/8	8 3/4	1205	759000	1518000	3600	18	6 21/32	7 21/32	11/32	7 13/32	7 15/32	11 1/2
7*	10 3/8	10	1840	1160000	2320000	3000	20 3/4	7 11/16	9	7/16	8 11/16	8 3/4	13 3/8

* Sizes 5 1/2, 6 and 7 are only available with exposed bolts. Type EB exposed bolts are standard.

① Floating shaft length is equal to the shaft separation minus 2 times the CFR dimension.

② Max. speed is based on flange stress limits and does not consider lateral critical speed considerations for floating shaft applications.

FLOATING SHAFT ASSEMBLY

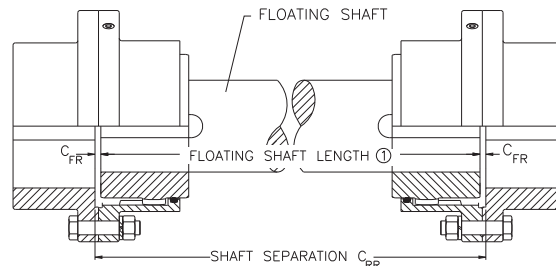

Ordering Instructions: When ordering floating shaft couplings, be sure to include hp and rpm, shaft separation, and equipment shaft sizes. Applications with very large shaft separations and/or high speeds may require tubular floating shafts due to lateral critical speed concerns.

Important: Care must be exercised in proper selection of any shaft coupling. The Users must assure themselves that the design of the shaft to coupling hub connection is adequate for the duty intended.